

# TGA2576-FL

## 2.5 to 6 GHz GaN HEMT Power Amplifier



### Applications

- Communications
- Electronic Warfare
- Test Instrumentation
- EMC Amplifier

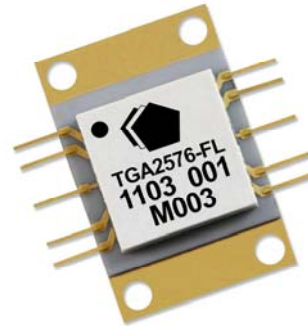

### Product Features

- Frequency Range: 2.5 – 6 GHz
- Psat: 45.5 dBm @ Pin = 26 dBm
- PAE: 35 %
- Small Signal Gain: 26 dB
- Bias: Vd = 30 V, Idq = 1.55 A, Vg = -3.3 V Typical
- Dimensions: 11.4 x 17.3 x 3.0 mm

### Functional Block Diagram

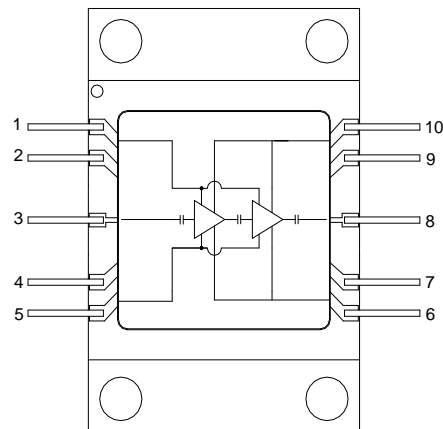

### General Description

TriQuint's TGA2576-FL is a packaged wideband power amplifier fabricated on TriQuint's production-released 0.25um GaN on SiC process. Operating from 2.5 GHz to 6 GHz, it achieves 45.5 dBm saturated output power, 35% PAE and 26 dB small signal gain.

Fully matched to 50 ohms and with integrated DC blocking caps on both I/O ports, the TGA2576-FL is ideally suited to support both commercial and defense related opportunities.

### Pin out Configuration

Pin #	Symbol
1,5	Vg
2,4,7,9	NC
3	RF In
6	Vd Bot
8	RF Out
10	Vd Top

### Ordering Information

Part No.	ECCN	Description
TGA2576-FL	3A001.b.2.a	2.5-6 GHz Power Amplifier

# TGA2576-FL

## 2.5 to 6 GHz GaN HEMT Power Amplifier



### Specifications

#### Absolute Maximum Ratings

Parameter	Rating
Drain to Gate Voltage, $V_d - V_g$	80 V
Drain Voltage, $V_d$	40 V
Gate Voltage, $V_g$	-10 to 0 V
Drain Current, $I_d$	4500 mA
Gate Current, $I_g$	-18 to 50 mA
Power Dissipation, $P_{diss}$	84 W
RF Input Power, CW, $50\Omega$ , $T = 25^\circ\text{C}$	28 dBm
Channel Temperature, $T_{ch}$	$275^\circ\text{C}$
Mounting Temperature (30 Seconds)	$260^\circ\text{C}$
Storage Temperature	-40 to $150^\circ\text{C}$

Operation of this device outside the parameter ranges given above may cause permanent damage. These are stress ratings only, and functional operation of the device at these conditions is not implied.

#### Electrical Specifications

Test conditions unless otherwise noted:  $25^\circ\text{C}$ ,  $V_d = 30\text{ V}$ ,  $I_{dq} = 1550\text{ mA}$ ,  $V_g = -3.3\text{ V}$  Typical.

Parameter	Min	Typical	Max	Units
Operational Frequency Range	2.5		6	GHz
Small Signal Gain		26		dB
Output Power @ Saturation		45.5		dBm
Power-added efficiency		35		%
Gain Temperature Coefficient		-0.04		dB/ $^\circ\text{C}$
Power Temperature Coefficient		-0.02		dBm/ $^\circ\text{C}$

#### Recommended Operating Conditions

Parameter	Min	Typical	Max	Units
$V_d$		30		V
$I_{dq}$		1550		mA
$I_{d\_drive}$ (Under RF Drive)		2500 - 3500	4000	mA
$V_g$		-3.3		V

Electrical specifications are measured at specified test conditions.  
Specifications are not guaranteed over all recommended operating conditions.

# TGA2576-FL

## 2.5 to 6 GHz GaN HEMT Power Amplifier



### Specifications (cont.)

#### Thermal and Reliability Information

Parameter	Condition	Rating
Thermal Resistance, $\theta_{JC}$ , measured to back of package	Tbase = 85 °C	$\theta_{JC} = 1.47$ °C/W
Channel Temperature (Tch), and Median Lifetime (Tm)	Tbase = 85 °C, Vd = 30 V, Idq = 1550 mA, Pdis = 46.5 W	Tch = 153 °C Tm = 5.5 E+7 Hours
Channel Temperature (Tch), and Median Lifetime (Tm) Under RF Drive	Tbase = 85 °C, Vd = 30 V, Id = 3000 mA, Pout = 44 dBm, Pdis = 64.9 W	Tch = 180 °C Tm = 6.3 E+6 Hours

Note: Thermal model to backside of package

### Median Lifetime (Tm) vs. Channel Temperature (Tch)

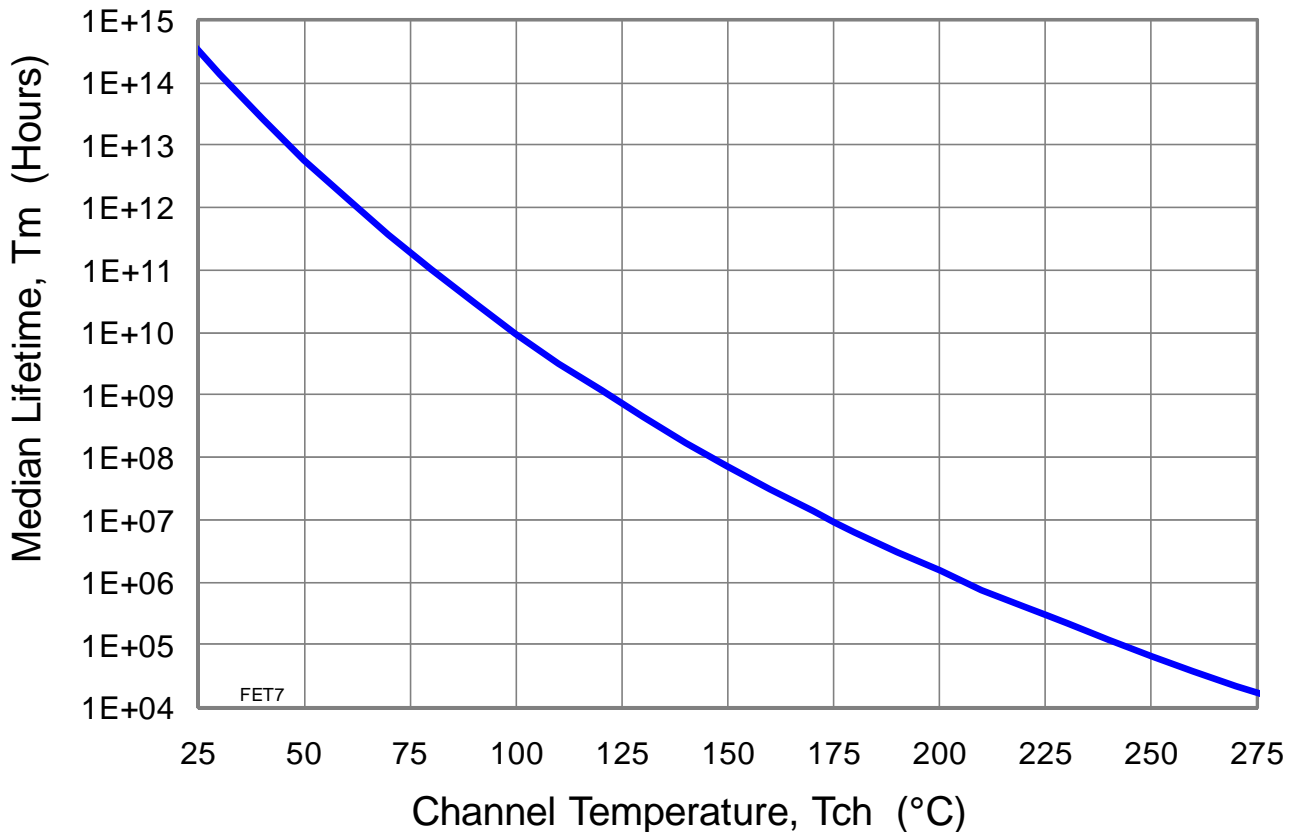

# TGA2576-FL

## 2.5 to 6 GHz GaN HEMT Power Amplifier



### Typical Performance

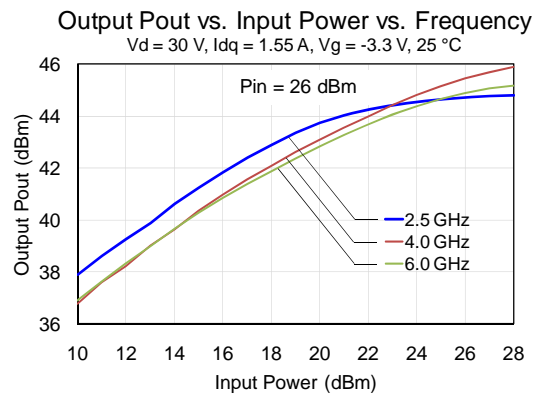
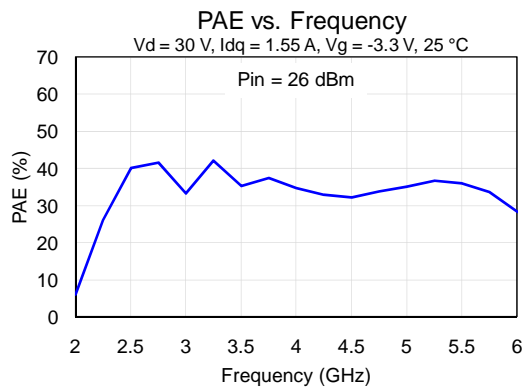
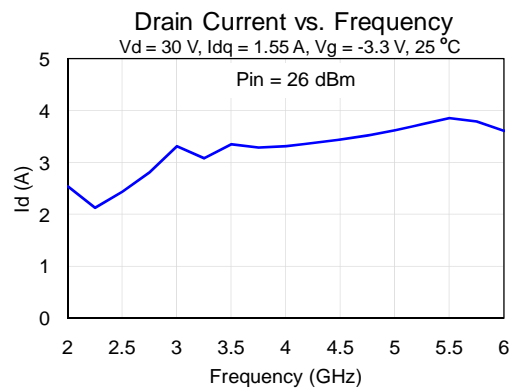
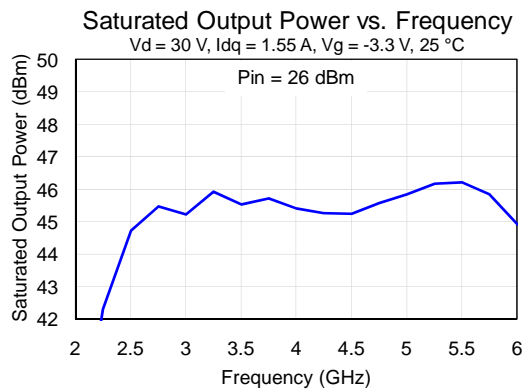
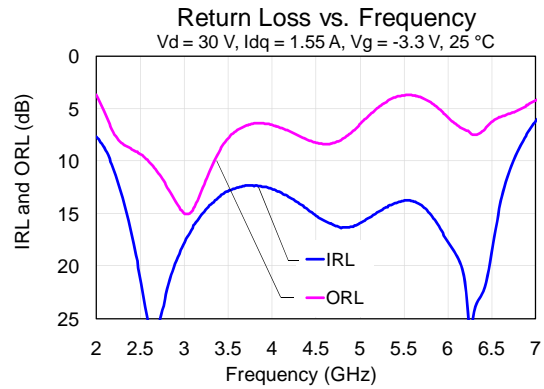
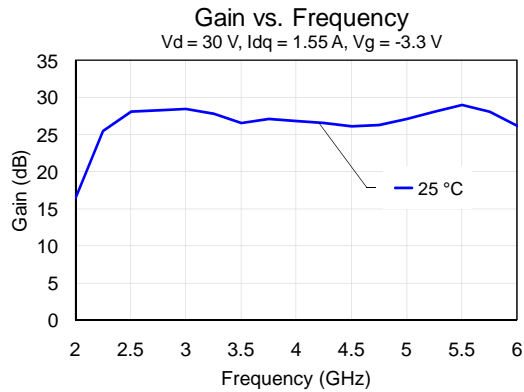

# TGA2576-FL

## 2.5 to 6 GHz GaN HEMT Power Amplifier



### Typical Performance (cont.)

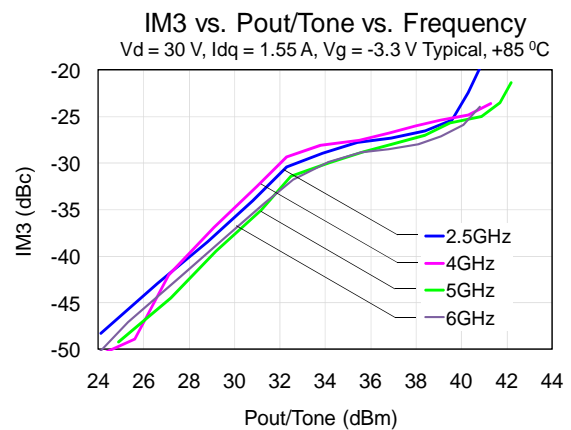
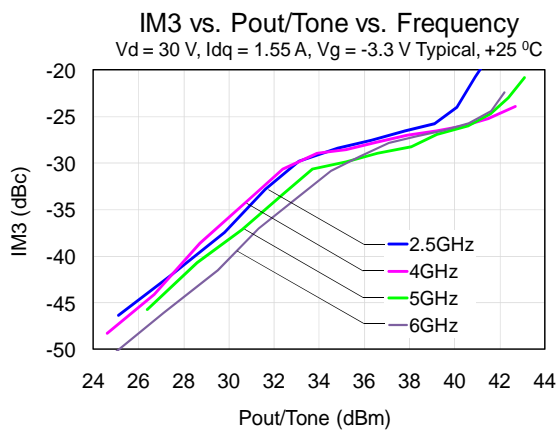
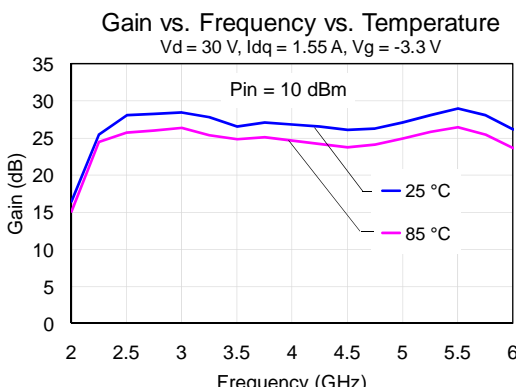
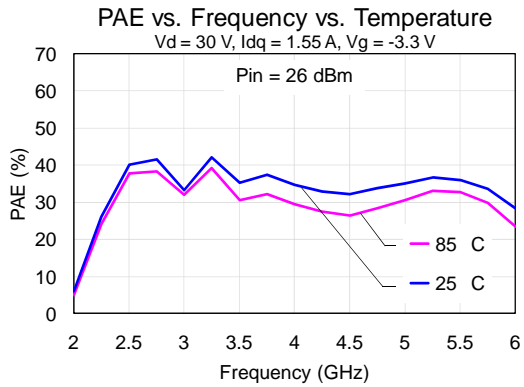
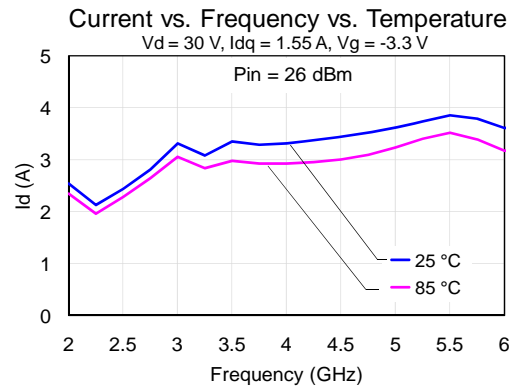
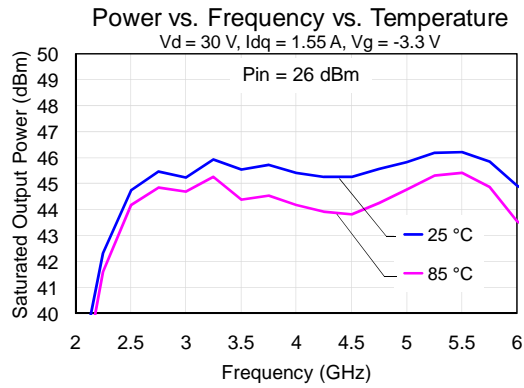

# TGA2576-FL

2.5 to 6 GHz GaN HEMT Power Amplifier

## Application Circuit

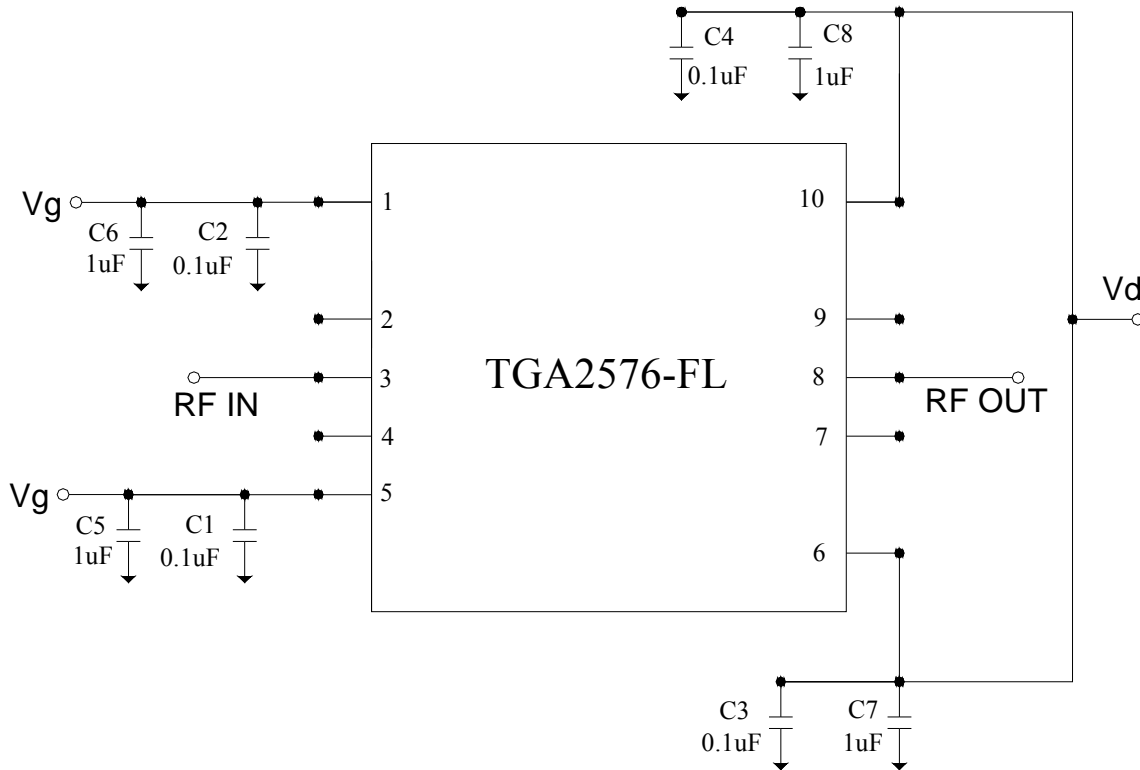

Vg can be biased from either side (pins 1 or 5).  
Vd must be biased from both sides (pins 6 and 10).

Bias-up Procedure	Bias-down Procedure
Vg set to -5.0 V	Turn off RF signal
Vd set to +30 V	Reduce Vg to -5.0 V. Ensure Id ~ 0 mA
Adjust Vg more positive until quiescent Id is 1400 mA. This will be ~ Vg = -3.3 V typical	Set Vd to 0 V
Apply RF signal	Set Vg to 0 V

# TGA2576-FL

## 2.5 to 6 GHz GaN HEMT Power Amplifier

### Pin Description

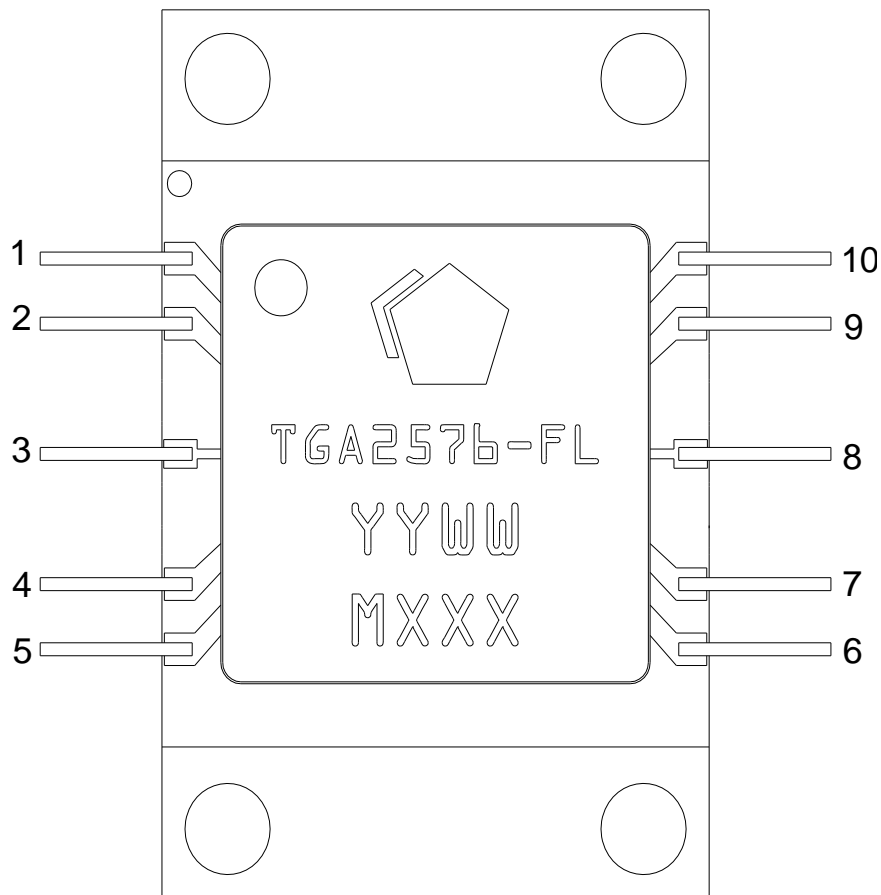

Pin	Symbol	Description
3	RF In	Input, matched to 50 ohms.
1	Vg	Gate voltage. See Note 1.
10	Vd Top	Top Drain voltage. See Note 2.
8	RF Out	Output, matched to 50 ohms.
6	Vd Bot	Bottom Drain voltage. See Note 2.
5	Vg	Gate voltage. See Note 1.
2,4,7,9	N/C	No internal connection; may be grounded or left open on PCB
	(Package Base)	RF and DC ground

Notes:

1. Bias network is required; can be biased from either side (pin 1 or pin 5); see Application Circuit on page 6 as an example.
2. Bias network is required; must be biased from both sides (pins 6 and 10); see Application Circuit on page 6 as an example.

# TGA2576-FL

2.5 to 6 GHz GaN HEMT Power Amplifier



## Evaluation Board Layout

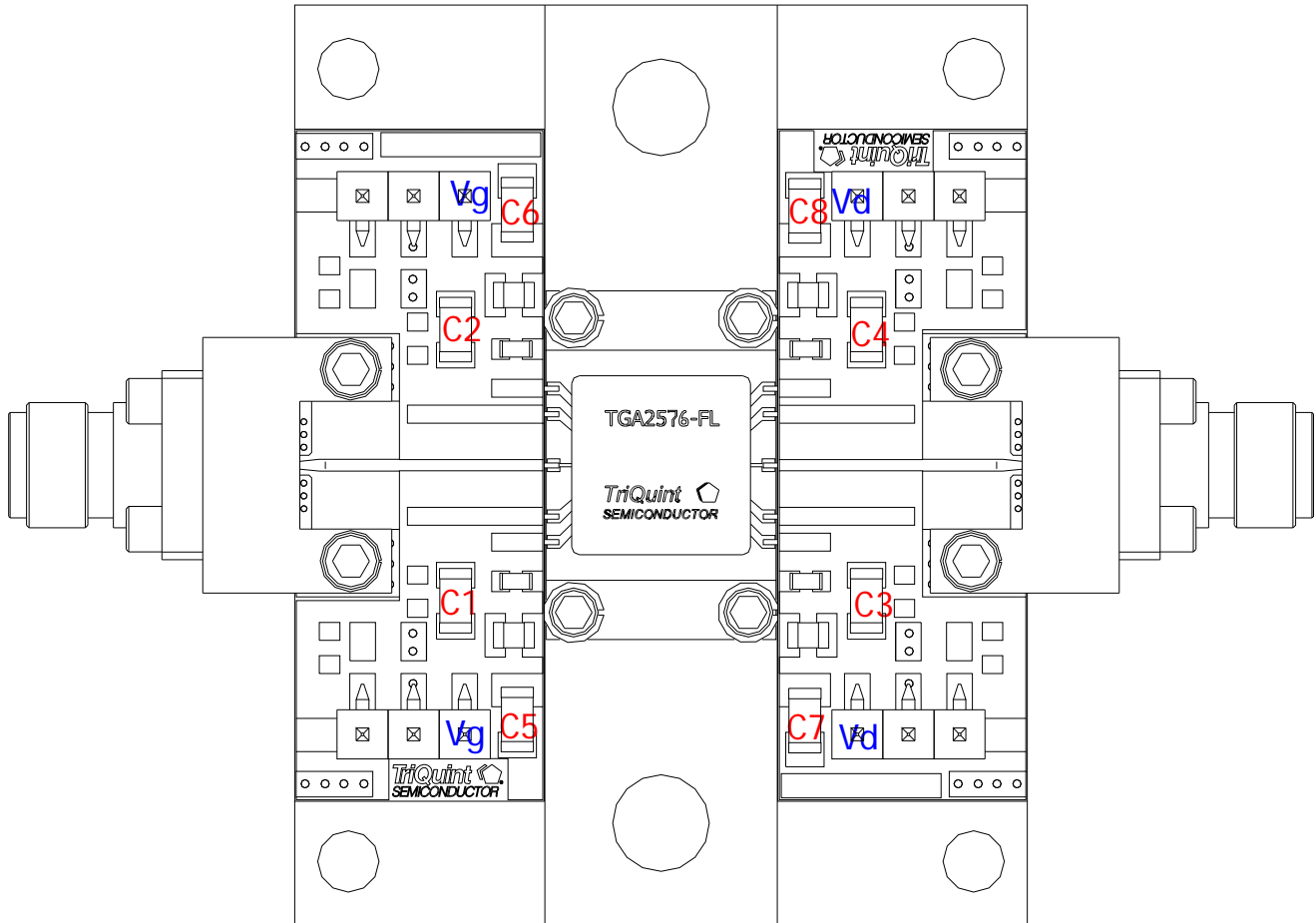

## Bill of Material

Ref Des	Value	Description	Manufacturer	Part Number
C1- C4	0.1 uF	Cap, 0603, 50V, 10%, X7R	various	
C5-C8	1 uF	Cap, 1206, 50V, 10%, X7R	various	



# TGA2576-FL

## 2.5 to 6 GHz GaN HEMT Power Amplifier



### Mechanical Information

#### Package Information and Dimensions

All dimensions are in millimeters.

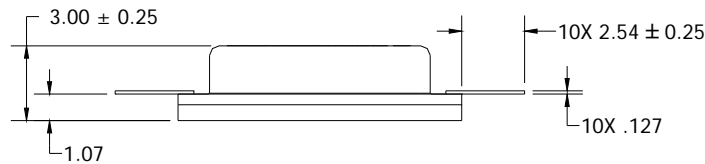
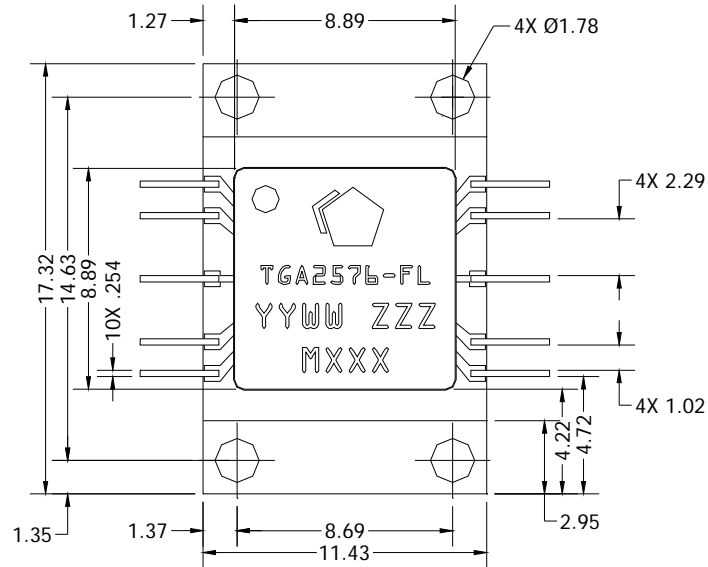

#### Notes:

1. Unless specified otherwise, dimensions are in millimeters
2. Unless specified otherwise, tolerance are +/- 0.127
3. Materials:

Package base:	Copper Tungsten (CuW) composite
Package lid:	LCP (liquid crystal polymer)
Package leads:	Kovar, MIL I 23011C Class 1
Plating Finish:	Gold (Au) 1.27um minimum over Nickel (Ni) 2.54-8.89um

4. Part Marking:

YY	Part Assembly Year
WW	Part Assembly Week
MXXX	Batch ID

## Product Compliance Information

### ESD Information



#### Caution! ESD-Sensitive Device

ESD Rating: TBD  
Value: Passes  $\geq$  TBD V min.  
Test: Human Body Model (HBM)  
Standard: JEDEC Standard JESD22-A114

### MSL Rating

Level TBD at +260 °C convection reflow  
The part is rated Moisture Sensitivity Level TBD at 260°C per  
JEDEC standard IPC/JEDEC J-STD-020.

### ECCN

US Department of Commerce 3A001.b.2.a

### Solderability

This product also has the following attributes:

- Lead Free
- Halogen Free (Chlorine, Bromine)
- Antimony Free
- TBBP-A (C<sub>15</sub>H<sub>12</sub>Br<sub>4</sub>O<sub>2</sub>) Free
- PFOS Free
- SVHC Free

## Assembly Notes

1. 0-80 screws are recommended for mounting the TGA2576-FL.
2. We recommend attaching a heat sink to the base of the TGA2576-FL. Use a thermal compound or 4 mils Indium shim between the heat sink and the TGA2576-FL base.
3. Apply solder to each pin of the TGA2576-FL.

# TGA2576-FL

## 2.5 to 6 GHz GaN HEMT Power Amplifier



### Contact Information

For the latest specifications, additional product information, worldwide sales and distribution locations, and information about TriQuint:

**Web:** [www.triquint.com](http://www.triquint.com)  
**Email:** [info-sales@tqs.com](mailto:info-sales@tqs.com)

**Tel:** +1.972.994.8465  
**Fax:** +1.972.994.8504

For technical questions and application information:

**Email:** [info-products@tqs.com](mailto:info-products@tqs.com)

### Important Notice

The information contained herein is believed to be reliable. TriQuint makes no warranties regarding the information contained herein. TriQuint assumes no responsibility or liability whatsoever for any of the information contained herein. TriQuint assumes no responsibility or liability whatsoever for the use of the information contained herein. The information contained herein is provided "AS IS, WHERE IS" and with all faults, and the entire risk associated with such information is entirely with the user. All information contained herein is subject to change without notice. Customers should obtain and verify the latest relevant information before placing orders for TriQuint products. The information contained herein or any use of such information does not grant, explicitly or implicitly, to any party any patent rights, licenses, or any other intellectual property rights, whether with regard to such information itself or anything described by such information.

TriQuint products are not warranted or authorized for use as critical components in medical, life-saving, or life-sustaining applications, or other applications where a failure would reasonably be expected to cause severe personal injury or death.